

# Measumax <sup>MX</sup>

## ELECTRONIC MICROMETER IP 65

### 10-1255, 10-1256

#### 1. Functional elements

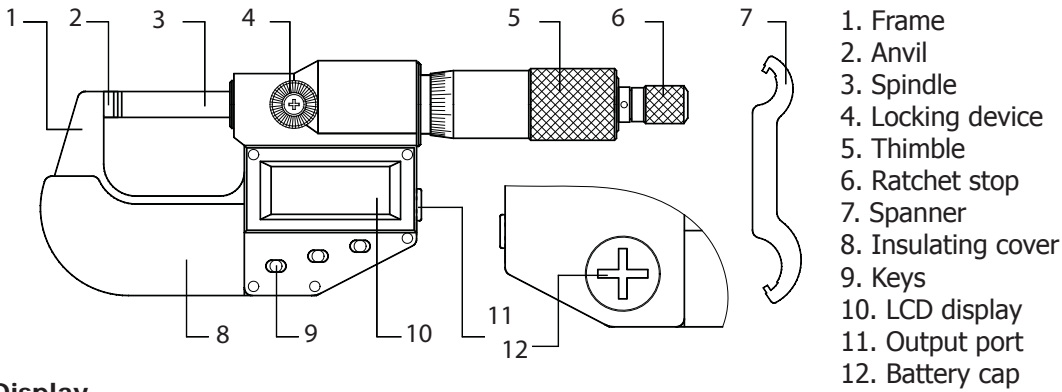

#### 2. LCD Display

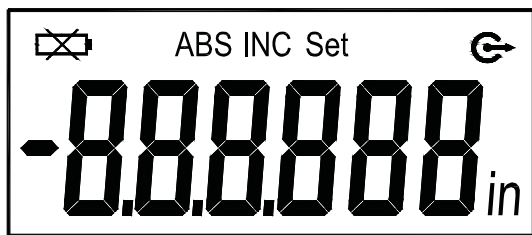

- in** : Inch mode
- INC** : Relative measuring
- ABS** : Absolute measuring
- : Battery voltage is low
- : Data output to PC
- Set** : Set the origin

#### 3. Operation

Two ways of pressing key are used in the following illustration:

- (1) Press and release.
- (2) Press and hold (more than 1 sec.).

##### 3.1 ON/OFF...SET

- ON/OFF Power on/off.

##### 3.2 ABS/INC...UNIT

- :ABS/INC Absolute/Relative measuring mode conversion.
- :UNIT Metric/Inch measuring mode conversion.

##### 3.3

- Output the data to PC once, "" flashes once.
- Output the data to PC continuously and "" keeps displaying. Press the key again to stop outputting.

#### 4. Set the Origin

##### 4.1 Set the Origin

Press and hold the "SET" key until the "Set" flashes once on LCD. The display is now set to the origin.

##### 4.2 Set a new origin (10-1256 only)

- a. Press and hold the "SET" key until "Set" flashes and the origin is displayed.
- b. Press and hold the "SET" key until "Set" disappears and the first digit starts flashing.
- c. Press the "SET" key, the flashing digit +1 until it is desired.
- d. Press and hold the "SET" key until the next digit flashes. Repeat steps c and d until the data on LCD is desired.
- e. Press and hold the "SET" key until "Set" flashes. Press the "SET" key, and the data on LCD will be set to the new origin. The origin will not be lost after replacing the battery.

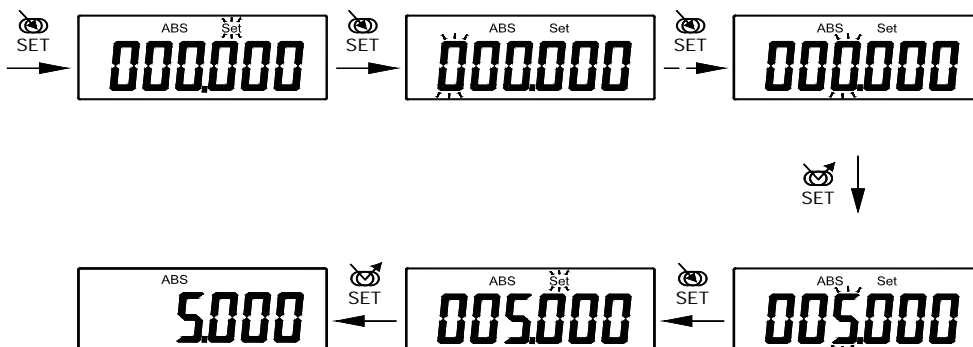

#### 5. Power

Battery is a SR44, 1.5V. Replace the battery when the display is blurring or "  " appears.

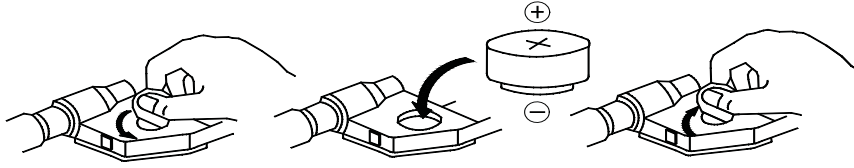

If not used for 5 minutes, the power will auto-off. The micrometer can be switch on by pressing the "ON/OFF" key or by turning the spindle.

Power off the micrometer by pressing "ON/OFF" key to save the battery if not in use.

#### 6. Data output

Data output interface is RS232C. The micrometer can be connected to PC's serial port by SPC cable. (Order No.40-400).

Series port format:

Baud rate	Start bit	Data bit	Stop bit	Parity	Data logic
1200	1	7	2	none	reverse

Data format:

Order	1	2	3	4	5	6	7	8	9	10
Metric	S	N1	N1	N	.	N	N	N	CR	LX
Inch	S	N	.	N	N	N	N	N	CR	LX

S: Minus or space

N1: Minus or space or digit 0-9

N: Digit 0-9

#### 7. Specifications

Measuring force : 5~10N

Power consumption : <=35μA

Operating temperature : 0 ~ 40□

Storage temperature :-20 ~ 60□

IP65 (Resist water spray)

#### 8. Precautions

Do not subject the gauge to blows or knocks• Do not drop the gauge or apply excessive force to the gauge• Do not disassemble the gauge• Do not press the key with a pointed object• Do not use or store the gauge under direct sunlight, or in an excessively hot or cold environment• Do not subject the gauge in strong magnetic fields and high voltage environment• Use a soft cloth or cotton rag when cleaning the gauge. Do not use any organic solvent such as acetone etc.• The spindle is designed so that it cannot be removed from the inner sleeve. Do not move it past the upper limit of the measuring range• Remove the battery if the gauge not in use for a long time

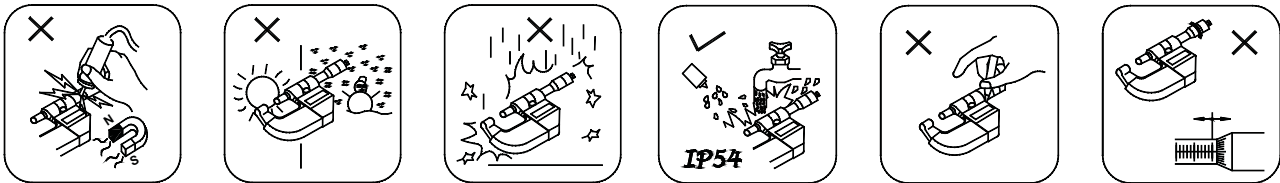

#### 9. Trouble shooting

Failure	Causes	Repairing
Display "E 1" Display "Exxxxx"	Measuring value over display range.	Reset the origin or convert to relative measuring mode.
Display "E 2"	The origin is too great.	Reset the origin.
Display "E 3" Display "E 8"	1. The micrometer is disturbed. 2. Something wrong with sensor.	1. Reset the battery. 2. Return the micrometer for repair.
Measuring value is not correct	1. Measuring surfaces are dirty. 2. The origin isn't correct.	1. Clean measuring surfaces. 2. Reset the origin.
Display is confusing or dead	Suffer to strong disturb.	Reset battery.
No display Display is blurring " " appears	Battery voltage under 1.45V.	Replace battery.
The output data is wrong	Battery voltage under 1.45V.	Replace battery.